

F. R. GOOLMAN.
WINDING MECHANISM FOR MUSIC SHEETS.

(Application filed Dec. 15, 1899.)

(No Model.)

2 Sheets—Sheet 1.

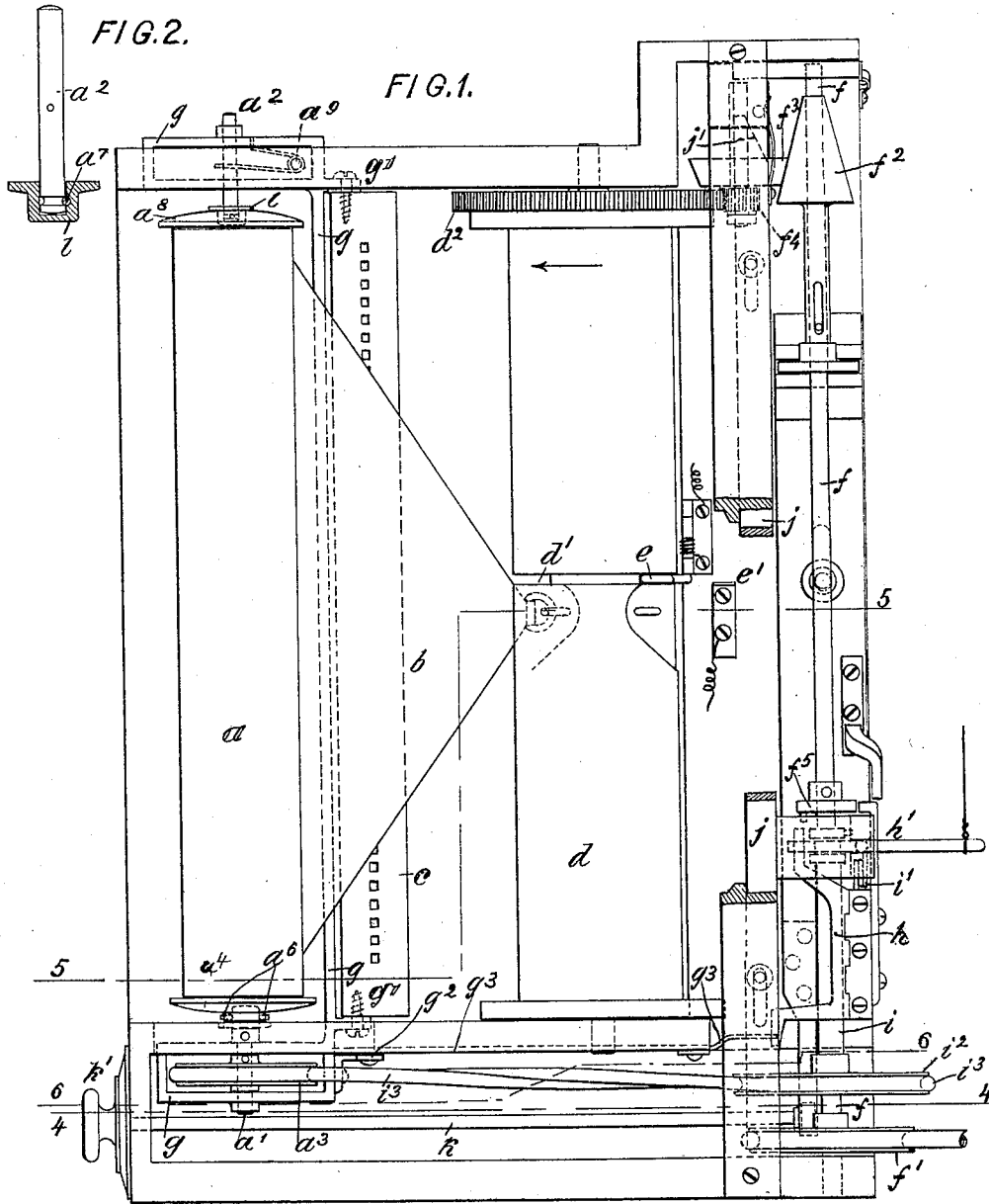

Witnesses:
John Becker
William Miller

Inventor:
Fred R. Goolman
 by his attorneys
Roeder & Briesen

F. R. GOOLMAN.
WINDING MECHANISM FOR MUSIC SHEETS.

(Application filed Dec. 15, 1899.)

(No Model.)

2 Sheets—Sheet 2.

FIG. 4.

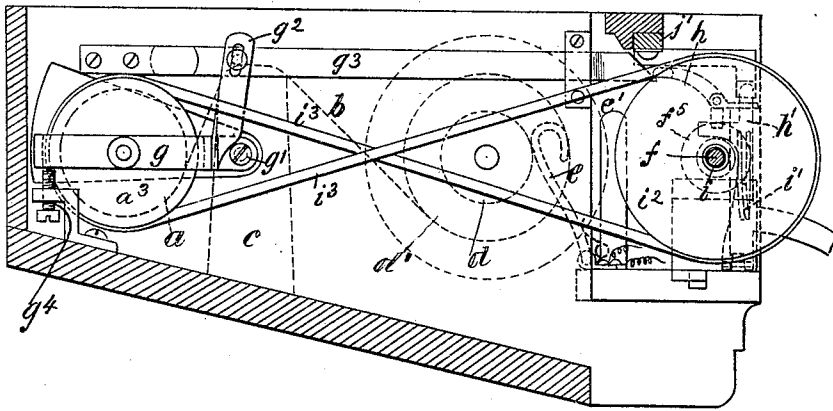

FIG. 5.

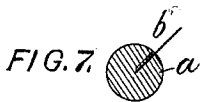
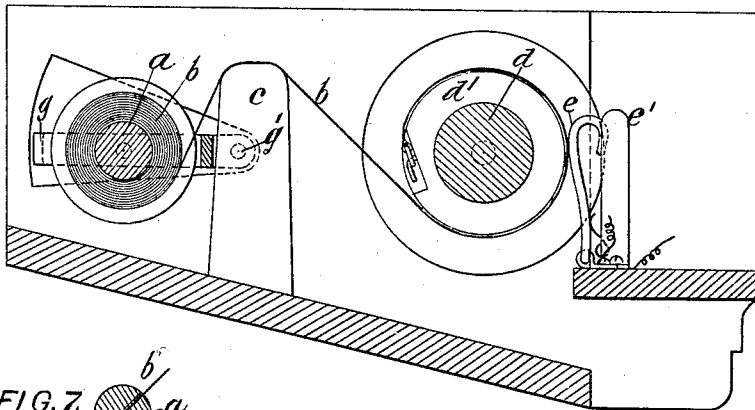
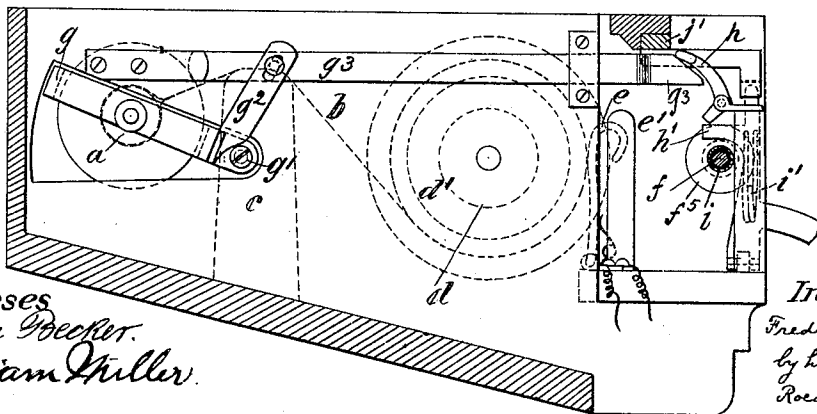

FIG. 6.



Witnesses
John Doecker.
William Miller.

Inventor:
Fred R. Goolman
by his attorneys
Roecker & Brienen

UNITED STATES PATENT OFFICE.

FRED R. GOOLMAN, OF ST. JOHNSVILLE, NEW YORK, ASSIGNOR TO
PEERLESS PIANO PLAYER CO., OF SAME PLACE.

WINDING MECHANISM FOR MUSIC-SHEETS.

SPECIFICATION forming part of Letters Patent No. 647,086, dated April 10, 1900.

Application filed December 15, 1899. Serial No. 740,385. (No model.)

To all whom it may concern:

Be it known that I, FRED R. GOOLMAN, a citizen of the United States, and a resident of St. Johnsville, Montgomery county, New York, have invented certain new and useful Improvements in Winding Mechanism for Music-Sheets, of which the following is a specification.

This invention relates to an improved winding mechanism for perforated music-sheets, such as is used for drawing the sheets over the air-duct bridge of a pneumatic piano and for other purposes.

The invention has for its objects to cause an automatic rewinding of the music-sheet from the receiving-drum upon the delivery-spool when the piece has been played, to automatically arrest the motor when the sheet has been thus rewound, and to start the motor when a new sheet has been properly adjusted.

In the accompanying drawings, Figure 1 is a plan, partly in section, of my improved apparatus; Fig. 2, a detail of spindle a^2 ; Fig. 3, an end view of head a^4 ; Fig. 4, a section on line 4 4, Fig. 1; Fig. 5, a section on line 5 5, Fig. 1; Fig. 6 a section on line 6 6, Fig. 1; and Fig. 7, a section through a modification of the delivery-spool a .

The letter a represents the delivery-spool, to which one end of the music-sheet b is attached by being pasted around such spool, Fig. 6, or by being secured within a slot of the same, Fig. 7. The sheet b passes over the air-duct bridge c or other means for actuating the sound-producers of a musical instrument, and thence to the receiving-drum d . This motor is provided with a circumferential groove d' , which serves for the reception of a resilient or hinged circuit-closing arm e , which when moved outward engages a contact-bar e' to close an electric circuit and start the motor that rotates the drum d .

In use the end of sheet b is attached to drum d and is wound partly around the same by hand, so as to cover groove d' and force the arm e out of such groove and into contact with bar e' , so as to place the motor in circuit. This motor by suitable transmitting mechanism—such, for instance, as described in Patent No. 603,184, granted to me April 26, 1898, and which is reproduced in the present appli-

cation—rotates the drum d upon turning a knob k' , and thus draws the music-sheet over bridge c . Briefly stated, this transmitting mechanism consists of the power-shaft f , driven from the motor by pulley f' and imparting motion by cone-pulleys f^2 f^3 and pinion f^4 to the gear-wheel d^2 of drum d . When the sheet b has been wound completely upon drum d , the reversing mechanism is automatically started by means hereinafter described to rewind the sheet upon spool a , and thereby uncover groove d' . This will release arm e and cause it to reënter the groove and break the circuit to stop the motor as soon as the sheet has been completely rewound.

The reversing and rewinding mechanism is of the following construction: The spindles a' a^2 of spool a turn in a swinging frame g , pivoted to fixed supports at g' and engaged by set-screw g^4 , which limits the tilting motion of the frame. The frame g is provided with an arm g^2 , rigidly connected to the frame g and engaging a slide g^3 , that in turn engages a clutch or shifting device. As soon as sheet b has been completely wound on drum d it will exert a strain or pull on spool a and will consequently tilt or oscillate frame g , to actuate the clutch or shifting device.

The shifting device is so constructed that when actuated it will at once uncouple drum d from driving-shaft f and will couple spool a to such shaft by a crossed belt, so that the spool a will rotate backward and will thus rewind the sheet b upon the spool. When the drum d has been bared from the sheet, the contact $e e'$ will be broken in the manner previously described and the motor stopped, so that the rotation of spool a ceases the moment the sheet has been rewound.

The clutch or shifting device for actuating the rewinding of the sheet upon the tilting of frame g may be of suitable construction and is similar to that shown in Patent No. 603,184, above referred to. Briefly stated, the slide tilts upwardly a pivoted frame h , that liberates a spring-actuated shifting lever h' and throws a hollow shaft i , by spring i' , into engagement with collar f^5 of shaft f . The hollow shaft i carries the pulley i^2 , which by a crossed belt i^3 and pulley a^3 rotates spindle a' of spool a to thus rotate such spool back-

ward. The normal tension of the belt i^3 will not tilt the frame g off the set-screw g^4 , because the latter should be so adjusted that the center of the spindle a' is in the same horizontal plane or below the center of the fulcrum g' . The shifting lever h' also moves a slide j , which by wedge j' throws sidewise the cone-pulley f^3 and disengages pinion f^4 from gear-wheel d^2 to uncouple drum d from shaft f .

After the sheet has been rewound upon spool a the latter may be removed and replaced by a spool carrying a new sheet, which is partly wound upon drum d , as already described, to reestablish contact $e e'$, and then the cone-pulley f^2 and slide j are returned to their normal position by turning knob k' on rod k to restart the instrument.

The spool a is rotatably mounted upon the spindles $a' a^2$ in the following manner: The head a^4 of the spool has a pair of notches a^5 , adapted to engage a pair of pins a^6 on spindle a' . The end of spindle a^2 is surrounded by a rotatable cap l , held thereto by a groove and a pin a^7 , the cap being adapted to be received within a corresponding socket of head a^3 . The spindle a^2 is normally pushed inward by a spring a^9 to hold the spool in place. To unseat the spool, it is moved toward the left by hand to crowd the spindle a^2 outward and disengage the head a^4 from pins a^6 .

What I claim is—

1. In a winding mechanism for music-sheets, a receiving-drum having a groove, combined with a spring-contact adapted to normally enter said groove, and with a music-sheet adapted to be wound upon the drum and displace said contact, substantially as specified.

2. In a winding mechanism for music-sheets, a receiving-drum having a groove, a spring-contact adapted to normally enter said groove, a second contact, a motor in circuit, and a music-sheet adapted to close the circuit when wound upon the drum, substantially as specified.

3. In a winding mechanism for music-sheets, the combination of a swinging frame with a delivery-spool hung therein, a receiving-drum, a music-sheet attached to the spool and adapted to be wound upon the drum, connections whereby the frame is tilted by the tension of the sheet, a slide connected to the frame, a motor adapted to be coupled to the drum, and a shifting device actuated by the slide and adapted to couple the motor to the spool and uncouple it from the drum, substantially as specified.

4. In a winding mechanism for music-sheets, the combination of a delivery-spool with a swinging frame, a grooved receiving-drum, a contact normally entering said groove, a motor in circuit when the contact is forced outward, a music-sheet secured to the spool and adapted to be wound upon the drum, and means for uncoupling the motor from the drum and coupling it to the spool upon tilting of the frame, substantially as specified.

Signed by me at St. Johnsville, Montgomery county, New York, this 21st day of June, 1899.

FRED R. GOOLMAN.

Witnesses:

ALFRED P. ROTH,
J. W. ROBERTSON.